

(TECHNICAL) PRODUCT INFORMATION

Cortes

Standard version

- ✓ Ideal low step-in and seat height.
- ✓ Easily operated hydraulic rear disc brakes.
- ✓ Integrated parking brake.
- ✓ Schwalbe anti-puncture tyres.
- ✓ Bright LED lighting at front and rear over battery pedal assistance.
- ✓ Available with various seating systems.
- ✓ AXA safety lock.
- ✓ Adjustable rear suspension.
- ✓ Smooth riding and steering thanks to differential on rear wheels.
- ✓ Low centre of gravity so very stable.
- ✓ Available with mid-motor, two types possible.

Colors

- Matt black (RAL 9005)
- Bright metallic blue (RAL5025)
- Ruby red with a fine texture (RAL3003)
- Custom RAL color at additional charge (excluding fluorescent colors).



Most common options & accessories

- Balance pedals
- Multiple seat systems
- Seat with adjustable backrest
- Rear-view mirror
- Stick holders

Find more options on the Cortes pricelist or configure your Cortes via the configurator on the website.

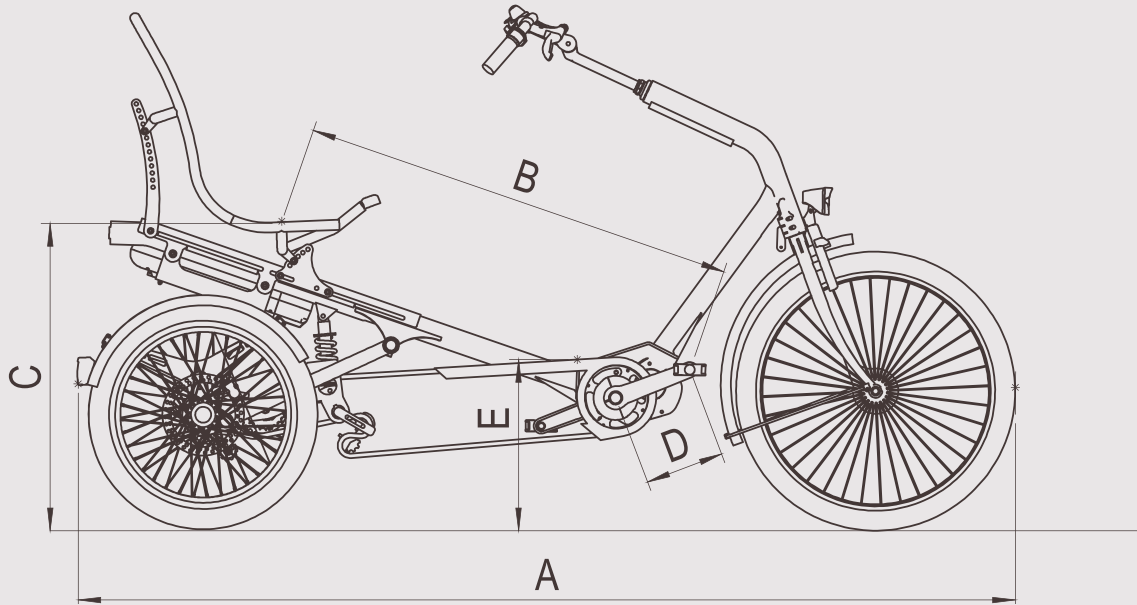

Other features

Standard

| | |
|----------------|---|
| Weight in kg | 48 |
| Material frame | anti-corrosion treated steel |
| Exterior | epoxy coating (less environmentally harmful) |
| Handlebar stem | adjustable, option with quick-release device |
| Rear wheel | 20" |
| Front wheel | 24" |
| Tyres | Schwalbe Marathon Plus (anti-puncture) |

Pedal support Bafang

| | |
|--------------------|---|
| Motor | Bafang M400 mid motor 80 Nm |
| Battery | Bafang 43V, 450Wh (option 750 Wh) lockable and removable |
| Sensor | power (Torque) |
| Display | large, colour display |
| Total weight in kg | 9 |

Pedal support Shimano STEPS

| | |
|--------------------|---|
| Motor | Shimano Steps E6100 mid motor 65 Nm |
| Battery | Shimano 36V, 418 Wh lockable and removable |
| Sensor | power (Torque) |
| Display | large, colour display |
| Total weight in kg | 9 |

Dimensions

| Part | |
|----------------------------|---------|
| Total length in mm (A) | 2065 |
| Seat height in mm (C) | 600-670 |
| Entry height in mm (E) | 360 |
| Width in mm | 785 |
| Inner leg length in mm (B) | 670-980 |
| Maximum load in kg | 150 |
| Crank length in mm (D) | 170 |

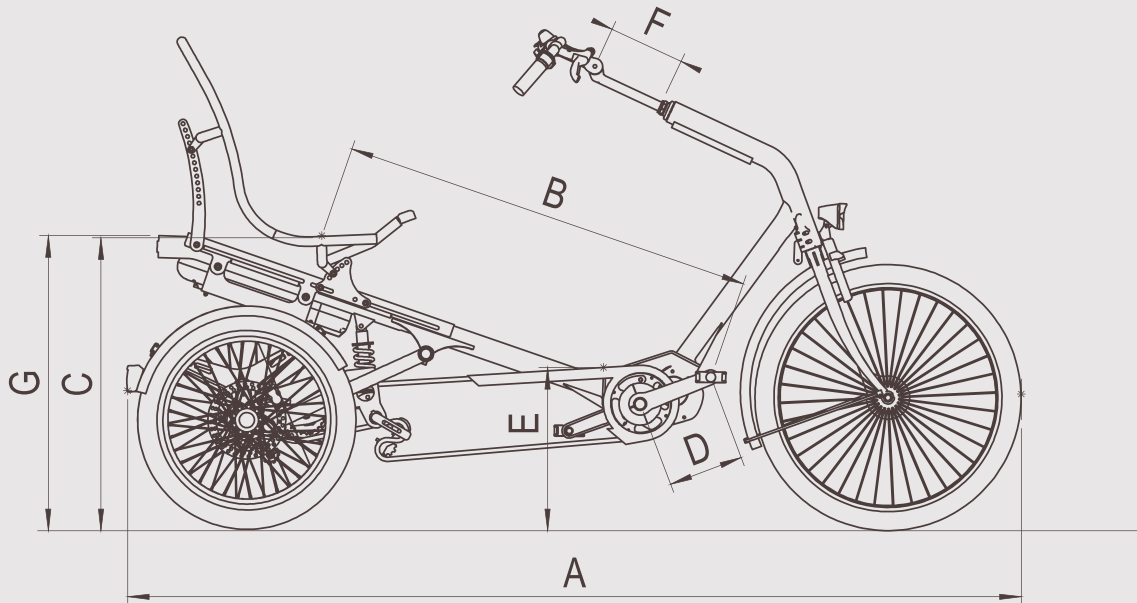

Other features

Standard

| | |
|----------------|---|
| Weight in kg | 48 |
| Material frame | anti-corrosion treated steel |
| Exterior | epoxy coating (less environmentally harmful) |
| Handlebar stem | adjustable, option with quick-release device |
| Front wheel | 24 x 2,15 (55-507) |
| Rear wheels | 20 x 1,75 (55-406) |
| Tyres | Schwalbe Marathon Plus (anti-puncture) |

Pedal support Bafang

| | |
|--------------------|---|
| Motor | Bafang M400 mid motor 80 Nm |
| Battery | Bafang 43V, 450Wh (option 750 Wh) lockable and removable |
| Sensor | power (Torque) |
| Display | large, colour display |
| Total weight in kg | 9 |

Pedal support Shimano STEPS

| | |
|--------------------|---|
| Motor | Shimano Steps E6100 mid motor 65 Nm |
| Battery | Shimano 36V, 418 Wh lockable and removable |
| Sensor | power (Torque) |
| Display | large, colour display |
| Total weight in kg | 9 |

Dimensions

| Part | |
|-----------------------------------|---------|
| Total length in mm (A) | 2065 |
| Seat high to the ground in mm (C) | 600-670 |
| Entry height in mm (E) | 360 |
| Width in mm | 785 |
| Inner leg length in mm | 600-980 |
| Maximum load in kg | 150 |
| Crank length in mm (D) | 170 |